

servomold®

# SLA LINEAR ACTUATORS



Motion  
for  
creation

COMPACT LINEAR ACTUATORS WITH EXCHANGEABLE  
SPINDLE AND HIGH-PERFORMANE SERVO MOTOR

# Servomold Linear Actuators SLA

## Product benefits at a glance

- 100% position and high repeat accuracy
- Continuously high forces and speeds, independent of the process state
- Movement profiles can be freely and individually defined and called up
- Clean, oil-free and therefore optimal cleanroom suitability
- Easy maintenance due to replaceable ball and roller screws
- Different power classes from 4kN to 60kN
- Compact and robust housing construction made of stainless steel

The new SLA-Compact series redefines performance and flexibility. With an innovative concept, it not only offers higher forces, but also impresses with its reduced dimensions – ideal for applications where space and efficiency are equally important.

Optimized for injection molding tools and more –  
Specially designed for use on injection molding tools, the SLA-Compact delivers outstanding results in demanding manufacturing processes. At the same time, it proves to be an excellent solution for classic automation tasks.

Individual configurations for the highest demands –  
The modular design and the integration of a wide range of servo motors and variable spindle systems make it possible to tailor the system to each application. This flexibility makes it possible to precisely meet specific customer requirements – regardless of whether it involves the highest speeds or maximum force.

## 100% Control

Servomold linear actuators, together with Servomold control units, allow precise, powerful and safe linear motion.

The advantages over hydraulic or pneumatic systems are many but can be summed up in one point - 100% control through the complete movement.

This allows an optimized design of the sequences in the injection molding process, but also the injection molds benefit from controlled and careful movements.

The results are less wear, lower maintenance requirements, and a significantly longer mold life.



# Applications

## New tools and retrofit

Servomold linear actuators are the perfect alternative to hydraulic or pneumatic cylinders, both for new molds and for retrofitting existing molds.

The application possibilities and areas of use are diverse - from slider and core movements to racks and plate movements, linear actuators.

## Sliders

For the movement of sliders, Servomold linear actuators can be used as individually controllable actuators or in any multiple combination with a single servo drive.

- Core pull and slider movements also possible in a closed mold
- Actuator can hold against injection pressure (calculation necessary)
- Multi-stage movements allow individual design of the demolding process
- Optional motor brakes for vertical arrangement prevent sagging of the mechanics when switching off the power

## Racks

Rack and pinion driven unscrewing molds are still very popular. With Servomold linear actuators, these can now be controlled powerfully, highly precisely and cleanly.

Permanent monitoring of the movement prevents damage to the mold and provides early indications of necessary maintenance or process changes.

This makes the linear actuators the safe and precise alternative to hydraulic cylinders.

## Plates, core pulls and more

The application possibilities are nearly unlimited. Our project team will help you with the selection and implementation of the linear actuators and give you helpful suggestions - this way, even special applications can be successfully realized.

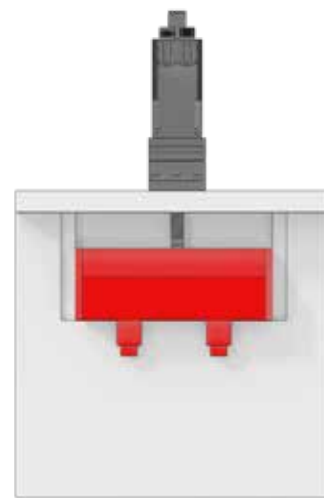

SLA-MC in vertical arrangement

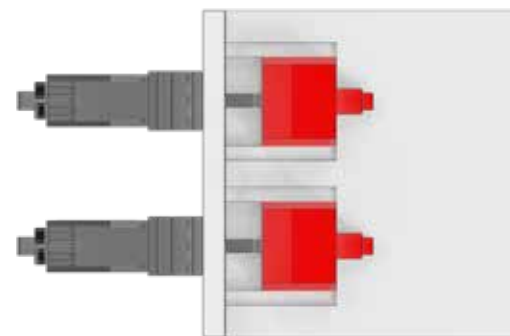

SLA-MC (2x) in horizontal arrangement

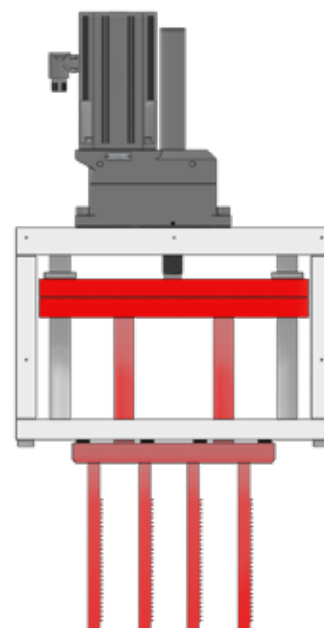

SLA-XLC

# Installation Examples

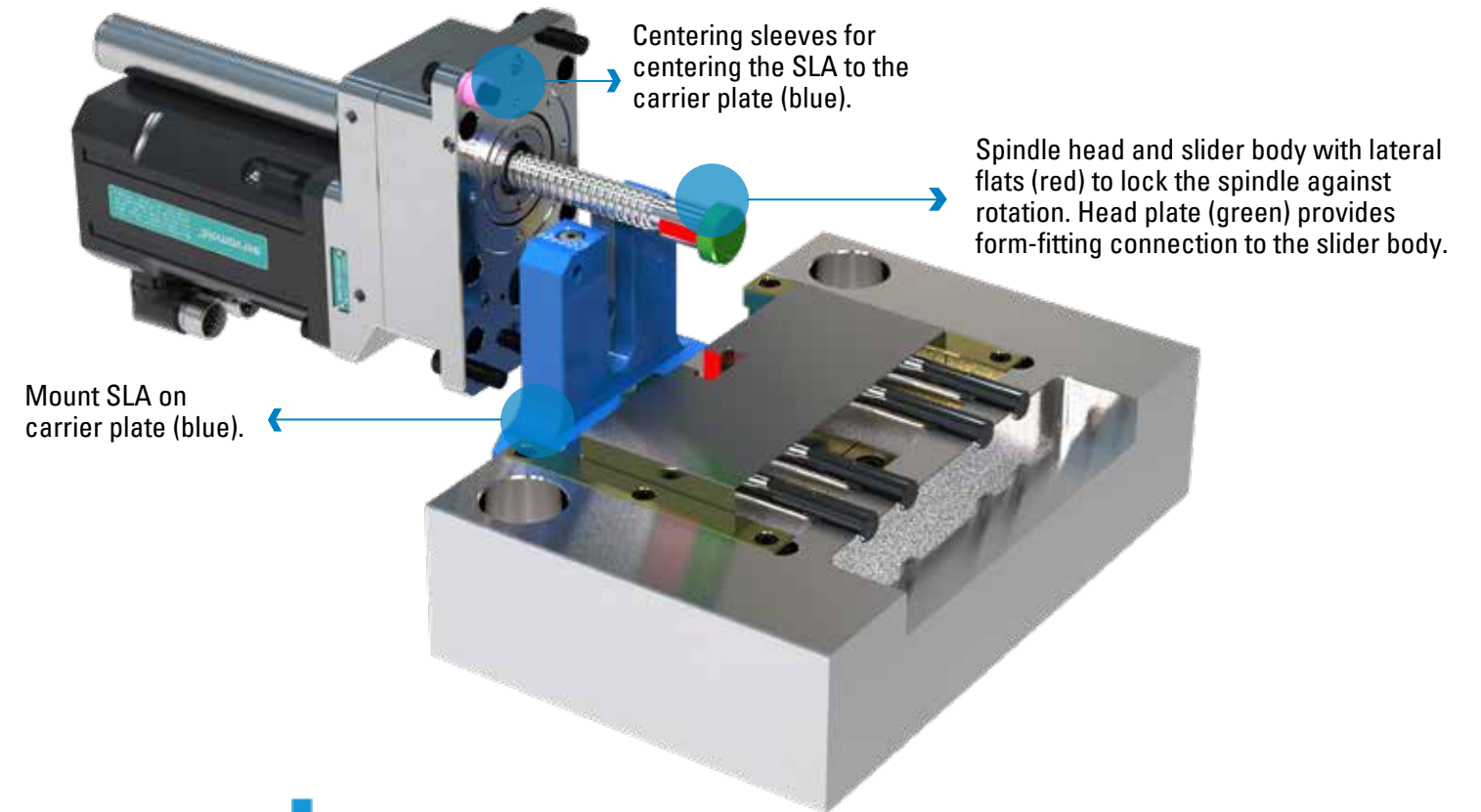

Mount SLA on carrier plate (blue).

Centering sleeves for centering the SLA to the carrier plate (blue).

Spindle head and slider body with lateral flats (red) to lock the spindle against rotation. Head plate (green) provides form-fitting connection to the slider body.

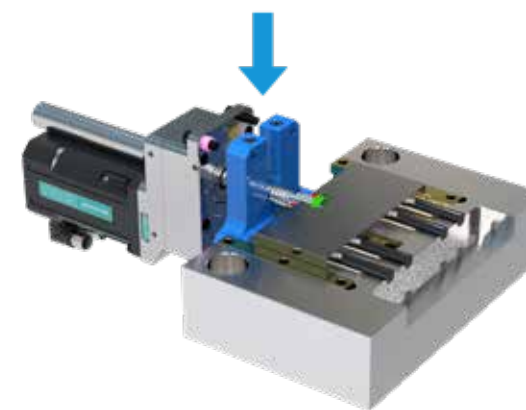

Insert spindle head with head plate (green) into slider body.

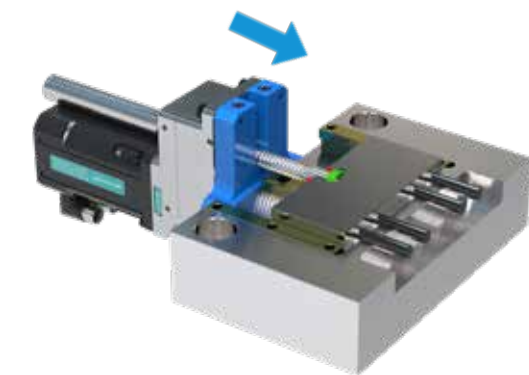

Push the SLA together with the slider body to the front and insert the centering sleeves. Screw the SLA to the carrier plate.

Customer examples carrier plate:  
The carrier plate is manufactured by the customer and must be cooled at mold temperatures >60°C.

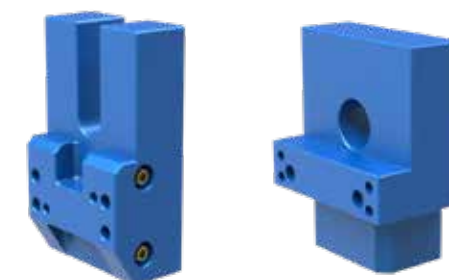

## Product Highlights SLA

### The compact SLA

The compact servo linear actuator SLA allows movements with stroke lengths up to 1000 mm and more. The linear actuator with exchangeable ball or roller screw and high-performance servo motor is a compact, powerful, energy-efficient and clean alternative to hydraulic or pneumatic cylinders for slider, core or plate movements.

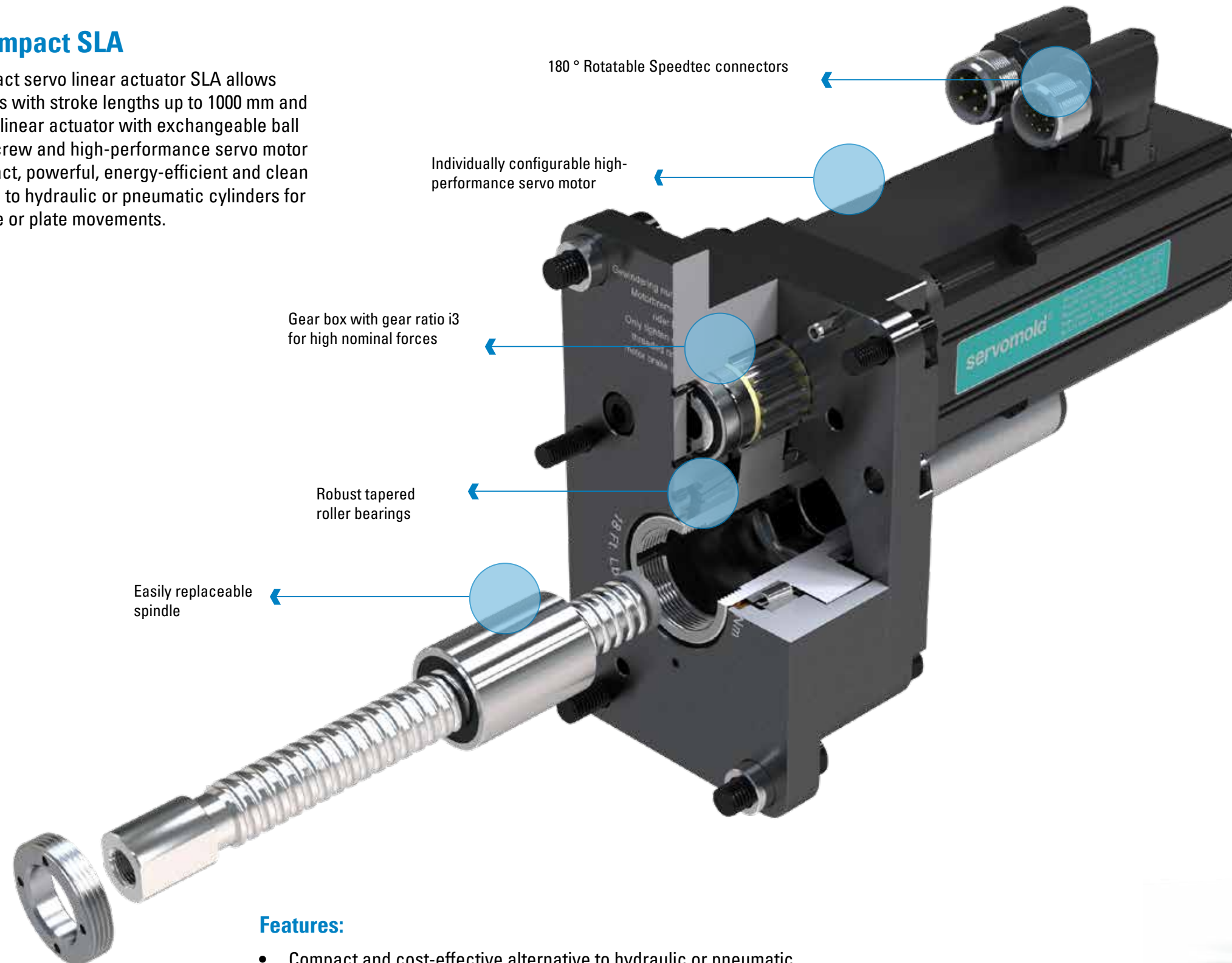

Patent pending

#### Features:

- Compact and cost-effective alternative to hydraulic or pneumatic cylinders - especially for slide movements
- Continuously high forces and speeds possible
- Attached, replaceable high-performance servo motor
- Easy maintenance due to replaceable ball screw spindle
- Compact overall length due to offset motor arrangement
- Different position encoder systems and optional holding brakes

### Mold Control

The Mold Control units including touch panel offer an innovative operating concept with which all important parameters and functions are displayed clearly and quickly accessible.



# Motor / Spindle

**Modular flexibility: diverse combination possibilities**

Motor option 1



Motor option 2



Standard  
High-performance  
Servo motor



Motor option 3



Motor option 4



Spindle option – roller screw spindle  
Pitch 5 / 10mm



Standard – ball screw spindle  
Pitch 5mm – stroke 150mm

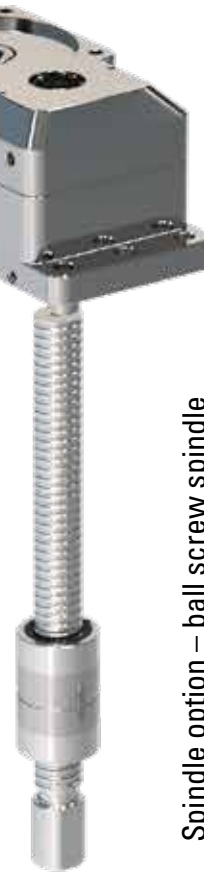

Spindle option – ball screw spindle  
Pitch 10mm stroke x



## Gear

Gear ratio for high nominal forces



## Ball or roller screw spindle

Ball or roller screw with pitch 2, 5, 10 or 20mm, configurable in any length and easily removable for maintenance.



## Servo motor

Servo motor with position encoder type resolver or absolute encoder as well as with additional holding brake available.



## References

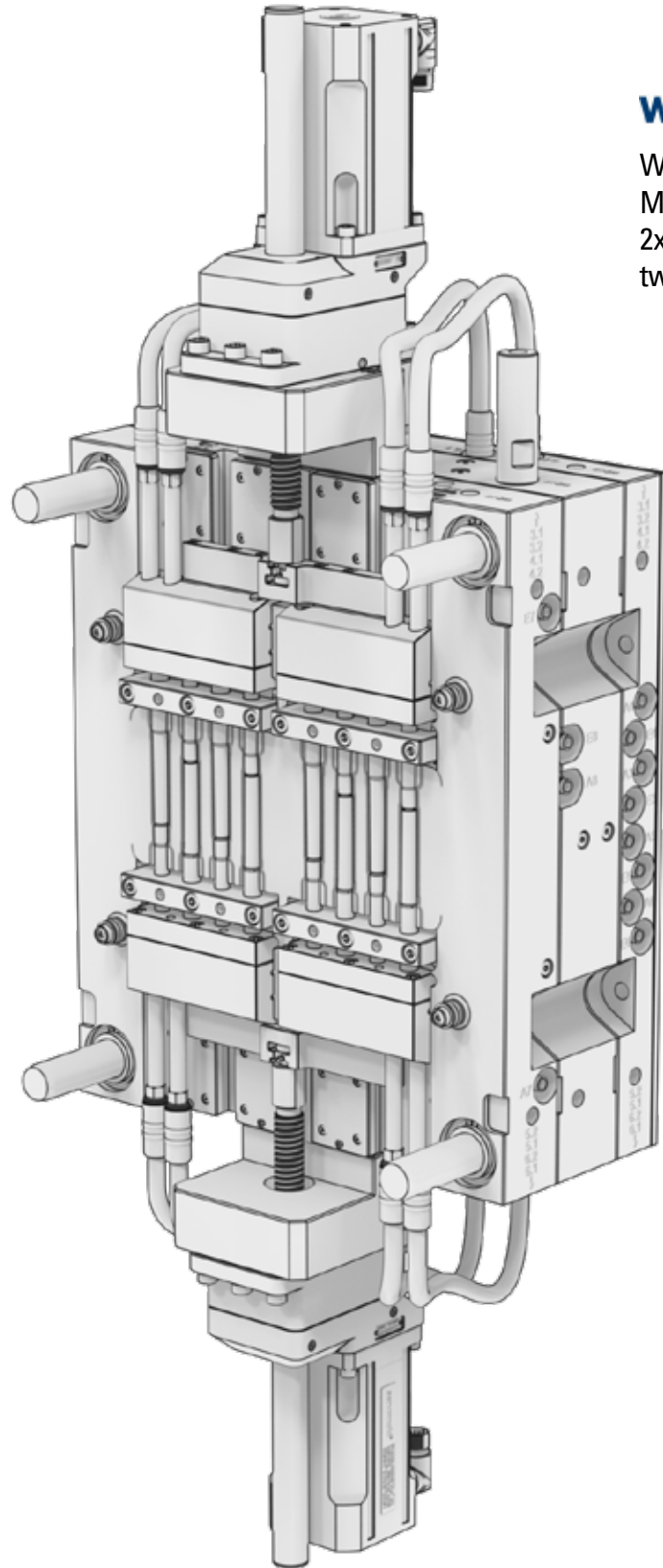

### WILD & KÜPFER

Wild & Küpfer AG  
Medical  
2x SLA-LC with 15 kN for moving  
two vertical sliders

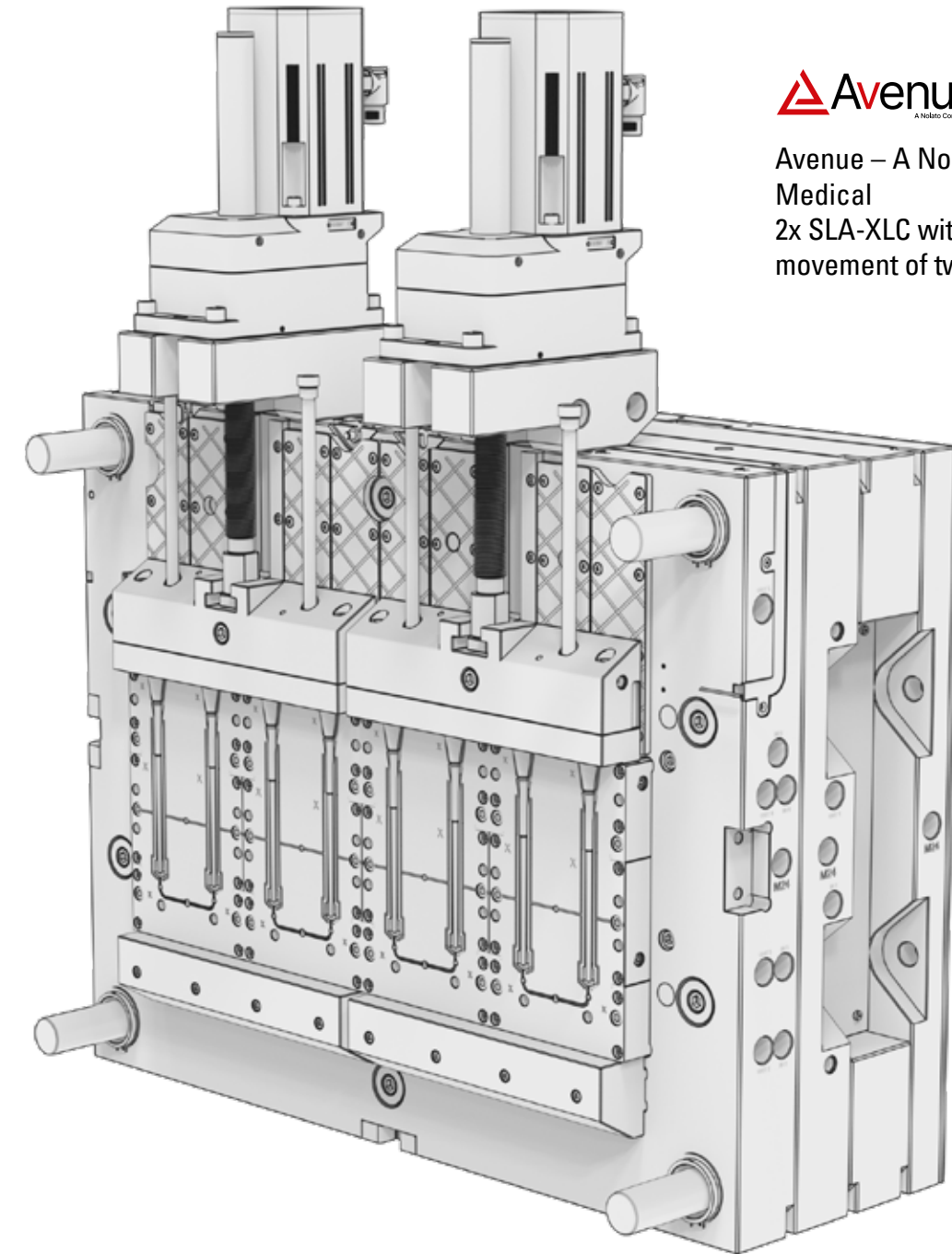

### Avenue

Avenue – A Nolato Company  
Medical  
2x SLA-XLC with 35 kN for the  
movement of two 4-fold sliders

# SLA Variants

## Size and configuration comparison

- Length depending on motor configuration and spindle length
- Maximum force depending on motor configuration, spindle pitch and motion profile
- KGT = Ball screw – for standard loads
- RGT = Roller screw – for higher loads and longer longevity
- Variants XLC and XXLC available with roller screw only

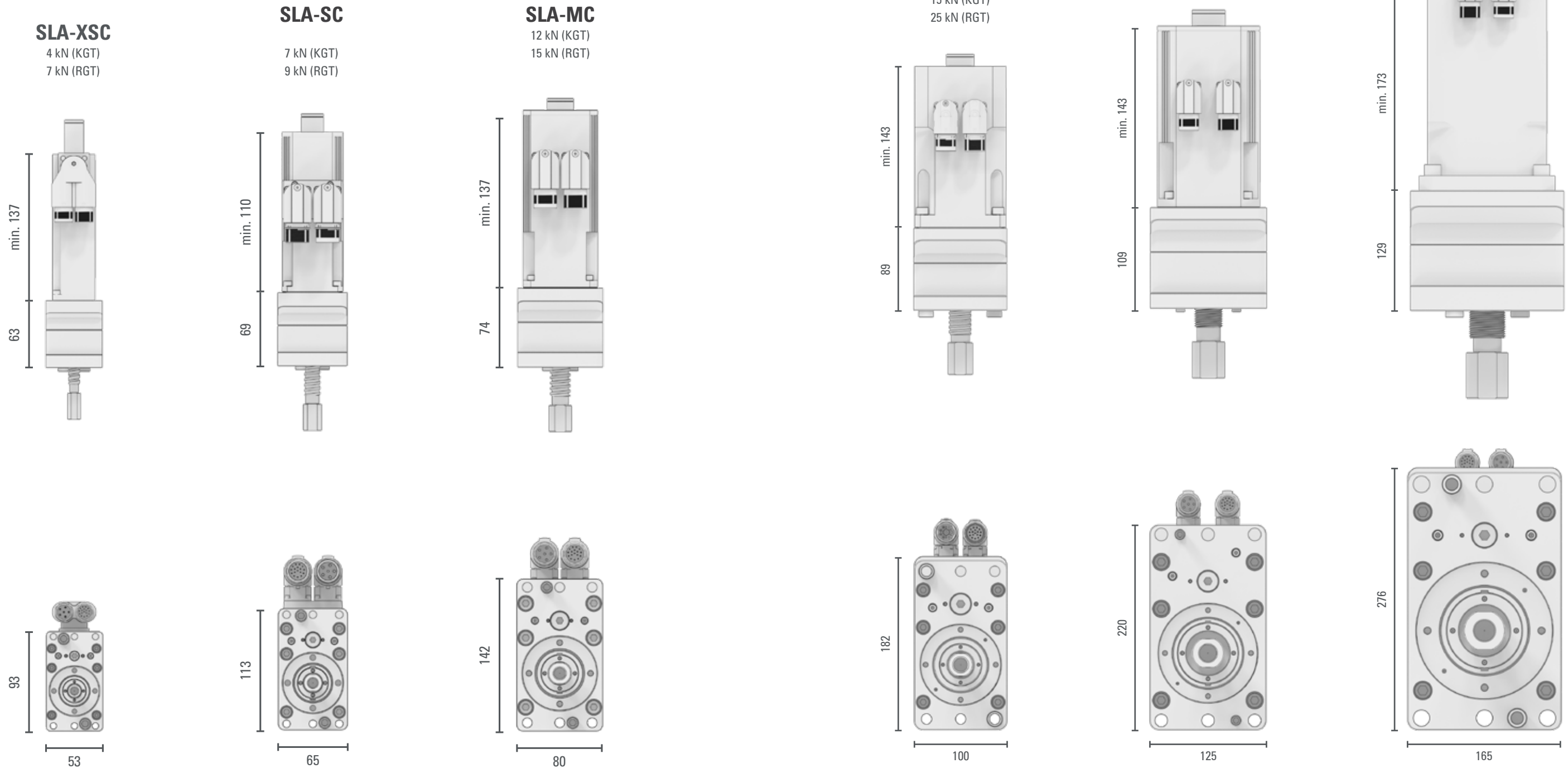

## SLA Variants

### Linear actuators – technical details (Standard configuration – spindle pitch 5mm pitch)

Variant	SLA-XSC	SLA-SC	SLA-MC	SLA-LC	SLA-XLC	SLA-XXLC
Ball screw spindle Variants	KGT-12	KGT-16	KGT-20	KGT-25	–	–
Roller screw spindle Variants	RGT-8**	RGT-12**	RGT-15**	RGT-20	RGT-30	RGT-39
Servo motor flange dimension [mm] (max. flange dimension)	40x40 (42x42)	57x57 (58x58)	70x70 (72x72)	98x98 (98x98)	98x98 (116x116)	142x142 (142x142)
Standard motor shaft Ø [mm] (max. motor shaft Ø)	Ø8 (Ø8)	Ø9 (Ø11)	Ø11 (Ø14)	Ø19 (Ø19)	Ø19 (Ø24)	Ø24 (Ø32)
Maximum force [N] KGT	4000	7000	12000	15000	–	–
Maximum force [N] RGT	7000	9000	15000	25000	35000	60000
nominal force [N] (motor-dependent)	1500	2500	6000	12000	20000	30000
Gearbox ratio	2,79	2,43	2,77	2,42	2,55	2,52
Max. speed [mm/sec.] (spindle pitch 5mm)	215-500 (motor-dependent)	400 (motor-dependent)	220-300 (motor-dependent)	230 (motor-dependent)	200-245 (motor-dependent)	240 (motor-dependent)
Weight [kg] motor variant resolver without brake	3	4	8	15	27	48
Load capacity of spindle bearing Dyn. [N]	17700	27500	34500	49000	88000	147000
Load capacity of spindle bearing Stat. [N]	23400	38000	52000	85000	125000	204000

\*\* Variant – not standard – delivery time and price on request

RGT spindle Ø8mm available with pitch 1, 2, 4 and 5mm – delivery time and price on request

RGT spindle Ø12mm available with pitch 1, 2, 4, 5 and 10mm – delivery time and price on request

RGT spindle Ø15mm available with pitch 2, 4, 5, 6, 8 and 10mm – delivery time and price on request

### Important

The technical data are based on the standard configuration (spindle pitch 5mm)!

All data dependent on linear actuator configuration and load profile!

XLC and XXLC versions available with roller screw only!

## KGT Spindle

### Ball screw spindle – technical details

Variant	Spindle Ø [mm]	Pitch [mm]	Dyn Load Cdyn [N]	Spindle nut Ø x L [mm]	Spindle head*	Head plate
KGT-12x5	12	5	8660	Ø21x47	Ø12,5x25//11-M8x1	Ø20x6-M8x1
KGT-12x10**	12	10	5950	Ø21x47	Ø12,5x25//11-M8x1	Ø20x6-M8x1
KGT-16x5	16	5	17600	Ø28x45	Ø17x25//14-M10x1	Ø24x8-M10x1
KGT-16x10**	16	10	11500	Ø28x45	Ø17x25//14-M10x1	Ø24x8-M10x1
KGT-20x5	20	5	24700	Ø34x55	Ø21,5x25//20-M12x1,5	Ø30x10-M12x1,5
KGT-20x10**	20	10	16900	Ø34x55	Ø21,5x25//20-M12x1,5	Ø30x10-M12x1,5
KGT-25x5	25	5	31400	Ø42x65	Ø27x35//24-M16x1,5	Ø38x12-M16x1,5
KGT-25x10**	25	10	18800	Ø42x65	Ø27x35//24-M16x1,5	Ø38x12-M16x1,5

\* Spindle head – Ø outer diameter x length // width lateral flattening – mounting thread

\*\* Variant – not standard – delivery time and price on request

## RGT Spindle

### Roller screw spindle – technical details

Variant	Spindle Ø [mm]	Pitch [mm]	Dyn Load Cdyn [N]	Spindle nut Ø x L [mm]	Spindle head*	Head plate
RGT-20x5	20	5	55000	Ø42x65	Ø27x35//24-M16x1,5	Ø38x12-M16x1,5
RGT-20x10**	20	10***	44400	Ø42x65	Ø27x35//24-M16x1,5	Ø38x12-M16x1,5
RGT-30x5	30	5	87000	Ø64x85	Ø35x40//30-M20x1,5	Ø50x15-M20x1,5
RGT-30x10	30	10***	101000	Ø64x85	Ø35x40//30-M20x1,5	Ø50x15-M20x1,5
RGT-39x5	39	5	123000	Ø80x100	Ø45x50//40-M24x1,5	Ø65x20-M24x1,5
RGT-39x10	39	10***	145000	Ø80x100	Ø45x50//40-M24x1,5	Ø65x20-M24x1,5

\* Spindle head – Ø outer diameter x length // width lateral flattening – mounting thread

\*\* Variant – not standard – delivery time and price on request

\*\*\* RGT spindle Ø20 also available with pitch 2, 4, 6, 12mm und 20mm – delivery time and price on request

RGT spindle Ø30 also available with pitch 2, 4, 6, 8, 20mm und 30mm – delivery time and price on request

RGT spindle Ø39 also available with pitch 2, 4, 20mm und 30mm – delivery time and price on request

### Important

The longevity of the spindle must be calculated for the specific application!

The basis of the calculation is the load profile as well as the temperature and quality of the lubrication!

No lateral forces may act on the spindle!

The spindle must be secured against rotation!

The spindle must not be removed from the spindle nut!

**With tens of thousands of products to choose from, DME is your one-stop shop for everything molding.** From complex undercuts solutions and plate control to standard pins, bushings and interlocks, the DME line of mold components will help you build or rebuild your mold base inside out, top to bottom. Industrial Supplies, Mold Bases, MUD Quick-Change, Control Systems, and Hot Runner solutions round out our extensive offering to truly be your one-stop shop.



#### **DME Company LLC**

42827 Irwin Dr.  
Harrison Twp., MI 48045  
**800-626-6653** toll-free tel  
**248-398-6000** tel  
**www.DME.net** web  
DME@DME.net e-mail

#### **DME Canada**

41 Todd Road  
Georgetown, Ontario  
Canada L7G 4R8  
**800-387-6600** toll-free tel  
**905-677-6370** tel  
DME\_Canada@DME.net e-mail

#### **DME Mexico / South America**

Circuito el Marques Notre, No.55  
Parque Industrial El Marqués  
El Marqués, Querétaro, CP 76246  
**52.442.760.2723/2710** tel  
DME\_MX@DME.net e-mail